

Product information presented here reflects conditions at time of publication. Consult factory regarding discrepancies or inconsistencies.



TECHNICAL DATA SHEET
EXPLOSION PROOF SERIES



Model X840/X841/X842 Grinder Pumps
 Class I, Division 1, Groups C & D
 Class I, Zone 1, Groups IIA and IIB



PRODUCT SPECIFICATIONS

MOTOR	Horse Power	2
	Voltage	200 - 575
	Phase	1 or 3 Ph
	Hertz	60 Hz
	RPM	3450
	Type	Capacitor start / capacitor run or 3 Ph
	Insulation	Class F
	Amps	4.5 - 20.0
PUMP	Operation	Nonautomatic
	Discharge Size	1-1/4" NPT vertical
	Cord Length	20' (6 m) standard
	Cord Type	UL listed, SOOW
	Max. Head	125' (38.1 m)
	Max. Flow Rate	54 GPM (204 LPM)
	Max. Operating Temp.	104 °F (40 °C)
	Cooling	Oil filled
MATERIALS	Motor Protection	Auto reset thermal overload (1 Ph) or thermal sensor (3 Ph)
	Cap	Cast iron
	Motor Housing	Cast iron
	Adapter	Cast iron
	Pump Housing	Cast iron
	Upper Bearing	Ball bearing
	Lower Bearing	Ball bearing
	Mechanical Seals	Carbon/ceramic with stainless steel parts
	Impeller Type	Non-clogging vortex
	Impeller	Ductile iron
	Hardware	Stainless steel
	Motor Shaft	Stainless steel
	Square Rings	Neoprene
	Cutter	Hardened 440 C stainless steel, Rockwell C55-60

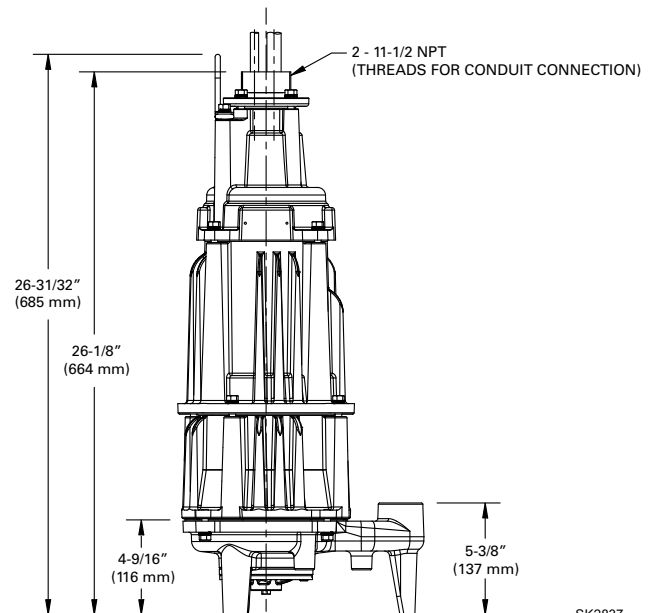
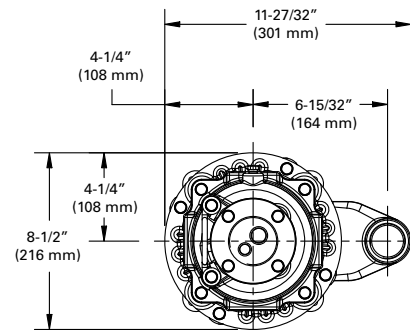

NOTE: See model comparison chart for specific details.



TOTAL DYNAMIC HEAD FLOW PER MINUTE

MODEL		X840		X841		X842	
Feet	Meters	Gal.	Liters	Gal.	Liters	Gal.	Liters
5	1.5	45	170	54	204	34	129
10	3.0	45	170	54	204	34	129
20	6.1	45	170	54	204	34	129
30	9.1	44	167	54	204	34	129
40	12.2	42	159	54	204	34	129
50	15.2	36	136	52	197	34	129
60	18.3	30	114	49	185	34	129
70	21.3	23	87	43	163	32	121
80	24.4	16	61	36	136	29	110
90	27.4	10	38	28	106	25	95
100	30.5	3	11	19	72	20	76
110	33.5	--	--	11	42	13	49
120	36.6	--	--	4	15	4	15
Shut-off Head:		104 ft (31.7 m)		125 ft (38.1 m)		125 ft (38.1 m)	

016532

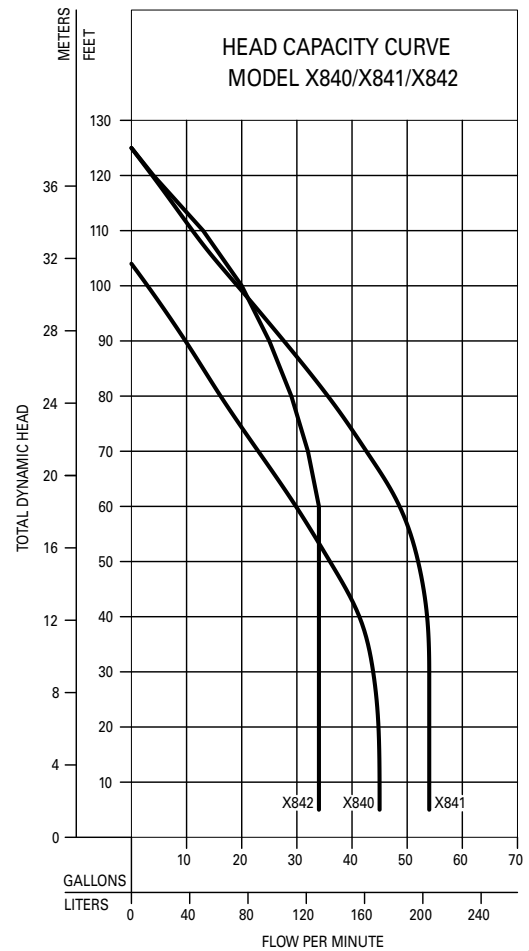

016532

Model	MODEL COMPARISON							
	Mode	Volts	Phase	Amps	HP	Hz	Lbs	Kg
IX840	Non	200	1	20.0	2	60	155	70
IX841	Non	200	1	20.0	2	60	155	70
IX842	Non	200	1	20.0	2	60	155	70
EX840	Non	230	1	17.2	2	60	155	70
EX841	Non	230	1	17.2	2	60	155	70
EX842	Non	230	1	17.2	2	60	155	70
JX840	Non	200	3	12.3	2	60	155	70
JX841	Non	200	3	12.3	2	60	155	70
JX842	Non	200	3	12.3	2	60	155	70
FX840	Non	230	3	10.8	2	60	155	70
FX841	Non	230	3	10.8	2	60	155	70
FX842	Non	230	3	10.8	2	60	155	70
GX840	Non	460	3	5.5	2	60	155	70
GX841	Non	460	3	5.5	2	60	155	70
GX842	Non	460	3	5.5	2	60	155	70
BAX840	Non	575	3	4.5	2	60	155	70
BAX841	Non	575	3	4.5	2	60	155	70
BAX842	Non	575	3	4.5	2	60	155	70

Model X840 is a reversible grinder pump, and models X841 and X842 are single-direction grinder pumps.



All installation of controls, protection devices and wiring should be done by a qualified licensed electrician. All electrical and safety codes should be followed including the most recent National Electrical Code (NEC) and the Occupational Safety and Health Act (OSHA).

GRINDER SYSTEMS

GRINDER MODELS X840/X841/X842 VERTICAL DISCHARGE - 20' (6 m) CORDS						
P/N	WGT.	MODEL	VOLTS	PH	AMP	
<input type="checkbox"/>	840-0064	155 lb (70.3 kg)	EX840	230	1 ϕ	17.2
<input type="checkbox"/>	840-0065	155 lb (70.3 kg)	IX840	200	1 ϕ	20.0
<input type="checkbox"/>	840-0066	151 lb (68.5 kg)	JX840	200	3	12.3
<input type="checkbox"/>	840-0067	151 lb (68.5 kg)	FX840	230	3	10.8
<input type="checkbox"/>	840-0068	151 lb (68.5 kg)	GX840	460	3	5.5
<input type="checkbox"/>	840-0069	151 lb (68.5 kg)	BAX840	575	3	4.5
<input type="checkbox"/>	841-0017	155 lb (70.3 kg)	EX841	230	1 ϕ	17.2
<input type="checkbox"/>	841-0018	155 lb (70.3 kg)	IX841	200	1 ϕ	20.0
<input type="checkbox"/>	841-0019	151 lb (68.5 kg)	JX841	200	3	12.3
<input type="checkbox"/>	841-0020	151 lb (68.5 kg)	FX841	230	3	10.8
<input type="checkbox"/>	841-0021	151 lb (68.5 kg)	GX841	460	3	5.5
<input type="checkbox"/>	841-0022	151 lb (68.5 kg)	BAX841	575	3	4.5
<input type="checkbox"/>	842-0011	155 lb (70.3 kg)	EX842	230	1 ϕ	17.2
<input type="checkbox"/>	842-0012	155 lb (70.3 kg)	IX842	200	1 ϕ	20.0
<input type="checkbox"/>	842-0013	151 lb (68.5 kg)	JX842	200	3	12.3
<input type="checkbox"/>	842-0014	151 lb (68.5 kg)	FX842	230	3	10.8
<input type="checkbox"/>	842-0015	151 lb (68.5 kg)	GX842	460	3	5.5
<input type="checkbox"/>	842-0016	151 lb (68.5 kg)	BAX842	575	3	4.5

Single phase units require a set of capacitors and relay starting components.

STANDARD FEATURES:

- cSAUs rated Class I, Division 1, Groups C & D and Class Zone 1, Groups IIA & IIB Construction
- Tested to FM standards 3600 and 3615 by CSA
- Reversible cutter action manual/auto**
- 1-1/4" NPT vertical discharge
- Carbon/ceramic tandem seals
- Thermal sensors** (overload on 1 Ph)
- Moisture probes**
- Vortex impeller: Ductile iron
- Stainless steel cutter and plate (R-C 55-60)
- Stainless steel shaft
- Stainless steel lifting bail
- Corrosion-resistant, powder coated epoxy paint
- 20' (6 m) power cord - 20' (6 m) sensor cord

OPTIONS:

- Extended cord lengths
- Bronze impeller
- Anti-siphon device

**Requires circuit in control panel to function
Reversible feature only available on X840 models

VARIABLE LEVEL FLOAT SWITCH ASSEMBLY

- 3 Switches with weights and brackets
- P/N 10-3237 WGT. 10 lb (4.5 kg)
- 4 Switches with weights and brackets
- P/N 10-3238 WGT. 14 lb (6.4 kg)

Note: All variable level float switches in this section are mechanically activated and do not contain mercury.

CONTROL PANELS					
SIMPLEX - NEMA 4 X			DUPLEX - NEMA 4X		
MODEL	P/N	WGT.	P/N	WGT.	
EX or IX840	<input type="checkbox"/> 10-2709	26 lb (11.8 kg)	<input type="checkbox"/> 10-2713	34 lb (15.4 kg)	
FX or JX840	<input type="checkbox"/> 10-2710	25 lb (11.3 kg)	<input type="checkbox"/> 10-2714	31 lb (14.1 kg)	
GX840	<input type="checkbox"/> 10-2711	25 lb (11.3 kg)	<input type="checkbox"/> 10-2715	31 lb (14.1 kg)	
BAX840	<input type="checkbox"/> 10-2712	25 lb (11.3 kg)	<input type="checkbox"/> 10-2716	31 lb (14.1 kg)	
EX or IX841, 842	<input type="checkbox"/> 10-2717	24 lb (10.9 kg)	<input type="checkbox"/> 10-2721	30 lb (13.6 kg)	
FX or JX841, 842	<input type="checkbox"/> 10-1568	24 lb (10.9 kg)	<input type="checkbox"/> 10-1596	27 lb (12.2 kg)	
GX841, 842	<input type="checkbox"/> 10-1560	24 lb (10.9 kg)	<input type="checkbox"/> 10-1588	27 lb (12.2 kg)	
BAX841, 842	<input type="checkbox"/> 10-2720	24 lb (10.9 kg)	<input type="checkbox"/> 10-2724	26 lb (11.8 kg)	

CONTROL PANEL

STANDARD FEATURES:

- NEMA 4X outdoor rating
- Intrinsically-safe relays
- Audible and visible high water alarm
- Starting, control, and alarm circuits
- Circuit breaker and rated motor contactor (1 Ph)
- Capacitors and motor starting relay (1 Ph)
- Motor-protective switch (circuit breaker/adj overloads) and rated motor contactor (3 Ph)
- Alternating circuit (duplex)
- Automatic reversing circuit (model X840 only)
- High water alarm light
- Internal seal leak light
- HOA switches and pilot light(s)
- Terminal strips
- Thermal cut-out circuit (3 Ph only)
- Padlock hasp
- UL listed
- Dry auxiliary contacts

OPTIONS:

- Flasher for high water alarm light
- Manual reset of high water alarm
- Elapsed time meters

For other options, please consult factory.

SIMPLEX REVERSING CONTROL BOXES*					
AUTOMATIC			MANUAL		
MODEL	P/N	WGT.	P/N	WGT.	
EX840	<input type="checkbox"/> 10-0352	8 lb (3.6 kg)	<input type="checkbox"/> 10-0360	7 lb (3.2 kg)	
IX840	<input type="checkbox"/> 10-0352	8 lb (3.6 kg)	<input type="checkbox"/> 10-0360	7 lb (3.2 kg)	
FX840	<input type="checkbox"/> 10-0353	6 lb (2.7 kg)	<input type="checkbox"/> 10-0361	5 lb (2.3 kg)	
JX840	<input type="checkbox"/> 10-0353	6 lb (2.7 kg)	<input type="checkbox"/> 10-0361	5 lb (2.3 kg)	
GX840	<input type="checkbox"/> 10-0353	6 lb (2.7 kg)	<input type="checkbox"/>	Not available	
BAX840	<input type="checkbox"/>	Not available	<input type="checkbox"/>	Not available	

*These control boxes consist of the reversing mechanisms and capacitors (1 Ph units) only. They will not control pumps. Refer to Section B for complete system controls. For duplex applications use two simplex reversing control boxes. (For pump prefix identification see News & Views 0052)

OUTDOOR BASIN, COVER, AND RAIL SYSTEM ASSEMBLIES STANDARD EQUIPMENT

- Fiberglass basin with anti-flotation ring
- (2) Steel electrical couplings
- 2" PVC discharge pipe from disconnect
- 2" Adaptaflex discharge pipe seal
- Non-sparking Z-Rail® disconnect system
- 8' (2.4 m) stainless steel lifting cable
- 3/4" stainless steel rail pipe
- For basin depths to 84" (213 cm) [2' (3.7 m) stainless steel lifting cable for basin depths of 96" (244 cm)]
- 2" PVC ball valve(s)
- 2" cast iron check valve(s)
- 1-4" rubber inlet pipe seal (field-installed)
- Blank fiberglass cover with Zoeller imprint

SIMPLEX

- | | |
|---------------------------|------------------------|
| □ 24" x 60" (61 x 152 cm) | P/N 33-0998 |
| | WGT. 189 lb (85.7 kg) |
| □ 24" x 72" (61 x 183 cm) | P/N 33-0999 |
| | WGT. 192 lb (87.1 kg) |
| □ 24" x 84" (61 x 213 cm) | P/N 33-1000 |
| | WGT. 213 lb (96.6 kg) |
| □ 24" x 96" (61 x 244 cm) | P/N 33-1001 |
| | WGT. 235 lb (106.5 kg) |

DUPLEX

- | | |
|---------------------------|------------------------|
| □ 36" x 60" (91 x 152 cm) | P/N 33-1002 |
| | WGT. 393 lb (178.2kg) |
| □ 36" x 72" (91 x 183 cm) | P/N 33-1003 |
| | WGT. 468 lb (212.2kg) |
| □ 36" x 84" (91 x 213 cm) | P/N 33-1004 |
| | WGT. 533 lb (241.7 kg) |
| □ 36" x 96" (91 x 244 cm) | P/N 33-1005 |
| | WGT. 593 lb (268.9 kg) |

- Larger diameter or deeper basins
(Allow for overhead clearance)

PUMP NOT INCLUDED

-- PREPACKAGED CHECKLIST --

SIMPLEX

- | | |
|--------------------------------|-----------|
| (1) Grinder pump | P/N _____ |
| (1) Simplex control panel | P/N _____ |
| (1) Float switch assembly | P/N _____ |
| (1) Prepackaged basin assembly | P/N _____ |

DUPLEX

- | | |
|--------------------------------|-----------|
| (2) Grinder pump | P/N _____ |
| (1) Duplex control panel | P/N _____ |
| (1) Float switch assembly | P/N _____ |
| (1) Prepackaged basin assembly | P/N _____ |

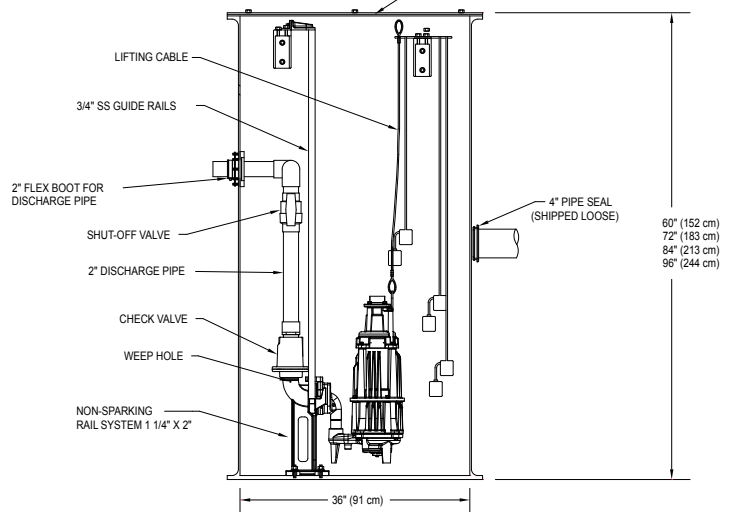
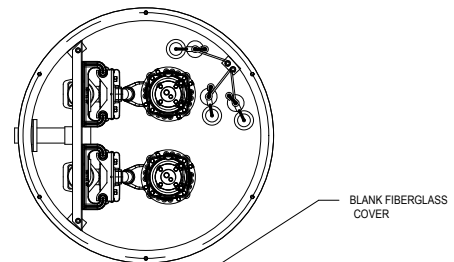
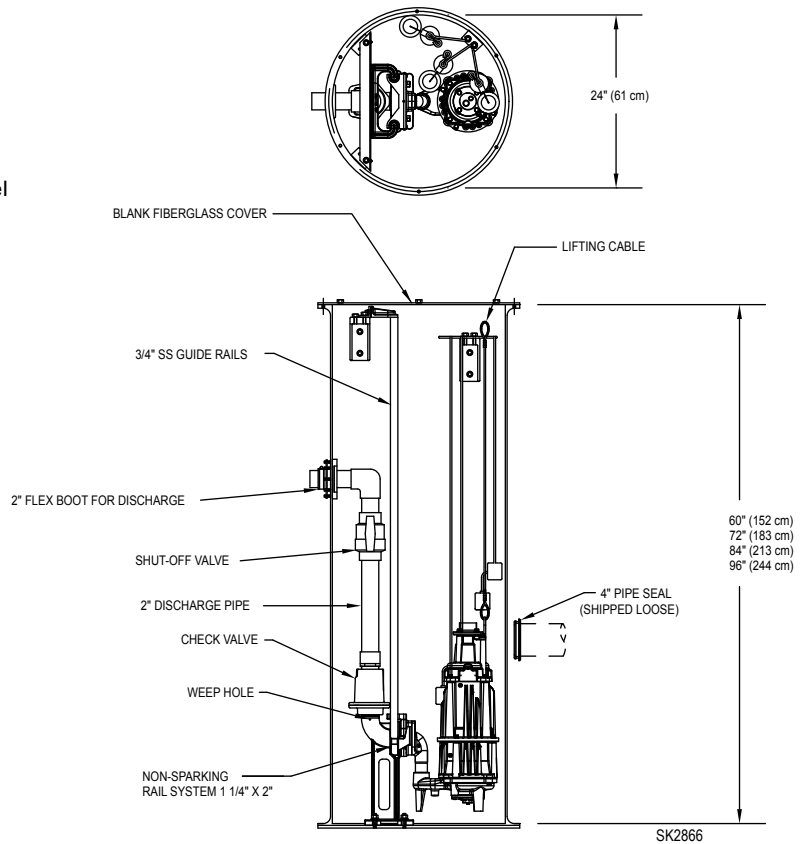

SK2867